

O-CI5XXXXYY-X-XX-X

Precision SC-cut OCXO in 1"x1" Through Hole Package

Product Data Sheet

Features

- SC-cut crystal
- High Stability (from 5 ppb)
- Low Aging (5×10^{-10} /day)
- Very Low Phase Noise (-135 dBc/Hz @ 10 Hz)

Applications

- Instrumentation
- Telecommunication Systems
- Data Communications
- GPS
- COTS/Dual use

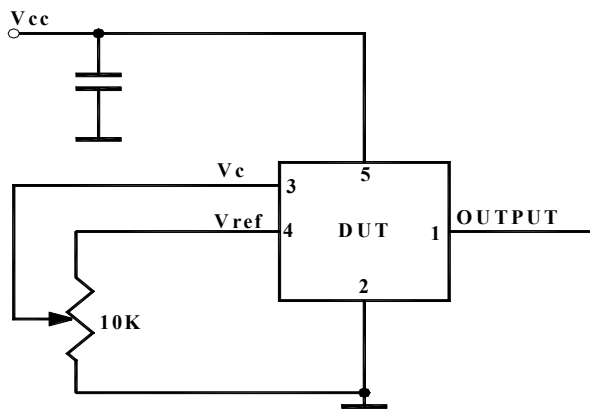
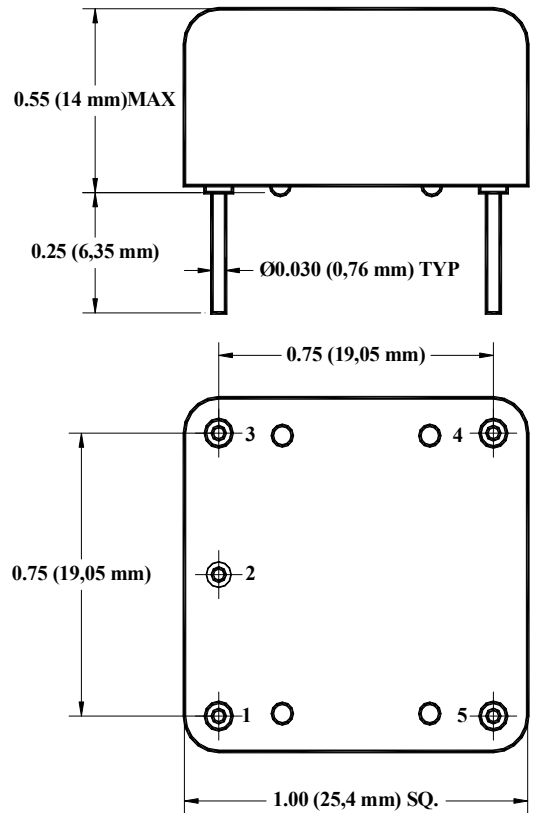

O-CI5XXXXYY-X-XX-X

Parameter	Symb	Condition	Min	Typ	Max	Unit	Note
<i>Absolute Maximum Ratings</i>							
Input Break Down Voltage	V _{cc}		-0.5 -0.5 -1.5		13.0 5.5 4.5	V	V _{cc} = 12 V V _{cc} = 5 V V _{cc} = 3.3V
Storage temper.	T _s		-40		85	°C	
Control Voltage	V _c		-1		12	V	

Electrical (3)

Frequency	F		8.0	10.000	20.000	MHz		All parameters for 10 MHz
Frequency stability	ΔF/F	vs. Temp., total excursion		10		ppb	Peak-to-peak See chart below	
		vs. Supply		1	2	ppb/5% V _{cc}		
Aging		per day per year, first year 10 years		5E-10 1E-7	3.5E-7		after 30 days 5E-8 available1*	
Allan Deviation		.1s to 1s		5E-12				
SSB Phase Noise		1Hz		-105	-100	dBc/Hz	2*	
		10 Hz		-140	-135			
		100 Hz		-156	-155			
		1 KHz		-163	-162			
		10 KHz		-169	-168			
		100 KHz		-170	-169			
Retrace		After 30 minutes			±10	ppb	24 hrs off	
G-sensitivity		worst direction			±1.0	ppb/G		
Input Voltage	V _{cc}	Code A	3.15	3.3	3.45	V	See chart below to specify	
		Code 0	4.75	5.0	5.25			
		Code F	11.4	12.0	12.6			
Power consumption	P	steady state, 25°C		0.7	1.0	W	Standard Operating Temperature, for Op Temp. 85 °C add 20% Still air for all	
		steady state, -30°C		1.5				
		start-up @ -30°C		2.5	3.2			
Spectral Purity		Subharmonics		none		dBc	Output Code S	
		Spurious			-80			
		Harmonics		-35	-30			
Load		Internally AC coupled 50 Ohm (Sinewave) 10K Ohm/15pf (CMOS/TTL)						
Warm-up time	τ	to 0.1ppm accuracy		3	5	minutes		
Output Power	P _{out}	Into 50 Ohm	7	10			Output Code S	
Logic 1 (CMOS)	V _{oh}		0.7V _{ref}			V	Output Code T	
Logic 0 (CMOS)	V _{ol}				0.1V _{ref}	V	Output Code T	
Duty Cycle			45/55		55/45	%	Output Code T	
Rise/Fall Time	T _r /T _f			3	5	ns	Output Code T	
Control voltage	V _c		0		10	V	Option ðLð Option ðPð Option ðSð	
			0		4.5			
			0		3.0			
Reference Voltage (Note 5)	V _{ref}			4.5 3.0		V	V _{cc} Code ð0ð; ðFð V _{cc} Code ðAð	
Pull range		from nominal F	±0.6 ±0.4 ±0.4	±0.8 ±0.6 ±0.6		ppm	Option ðLð Option ðPð Option ðSð	
Deviation slope		Monotonic, posit.		0.16 0.27 0.4		ppm/V	Option ðLð Option ðPð Option ðSð	
Input impedance	Z _{in}	At V _c pin	10			KOhm		
Modulation bandwidth	F _m		DC		1	KHz	Note 4	

Stability	Vc0	@25°C, Fnom.	4.5 2.0 1.25	5.0 2.25 1.5	5.5 2.5 1.75	V	Op.δLö, No internal bias Option δPö Option δSö
Initial Calibration		@25°C			±100	ppb	

Environmental and Mechanical

Operating temp. range	0°C to 70°C Standard, Other options ó see chart below
Mechanical Shock	Per MIL-STD-202, 30G, 11ms
Vibration	Per MIL-STD-202, 5G to 2000 Hz
Soldering Conditions	260°C for 10s Max leads only

Electrical Connections

Pin Out	Pin #1-- Output ; Pin#2 ó GND; Pin #3 ó Vc; Pin #4 ó Vref ⁽⁵⁾ or N/C; Pin #5 - Vcc;
----------------	--

Notes:

1. Aging rates are proportional to the operating frequency. Pull range will be adjusted accordingly to provide for lifetime possibility to set on frequency
2. Close to the carrier phase noise deteriorates with increase in frequency.
3. All parameters, unless otherwise specified, are at nominal conditions, ie: T=25°C, Nominal Vcc & Nominal Load.
4. Older and stock units may have MBW of 150 Hz Max.
5. Reference Voltage output only available with Option P Deviation Slope/Control Voltage.

Creating a Part Number

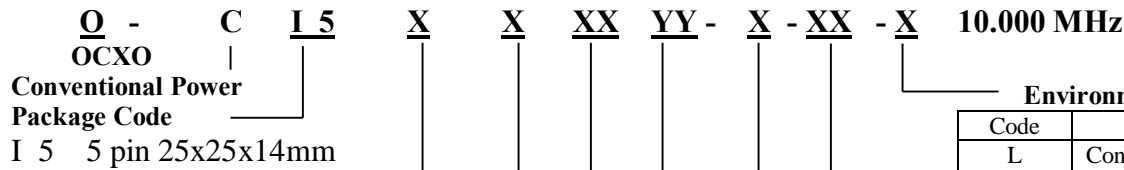

Supply Voltage

Code	Specification
A	3.3V TYP
0	5 V TYP
F	12V TYP

Output

Code	Specification
S	Sinewave
T	CMOS/TTL

**Temperature Stability,
Total excursion, pk-pk**

Code	Specification
17	1x10 ⁻⁷
58	5x10 ⁻⁸
28	2x10 ⁻⁸
18	1x10 ⁻⁸
YZ	Yx10 ^{-Z}

Environmental

Code	Specification
L	Contains a level of lead that is in excess of RoHS directive and is not designed for reflow
R	RoHS compliant, not designed for reflow

Aging per year, 1st year

Insert value per year x 1E-8	
Examples	
05	5E-8
10	1E-7

Control Voltage

Code	Specification
L	0 to 10 V
P	0 to 4.5 V Vcc=5V
S	0 to 3.0V Vcc=3.3V

Temperature Range

Code	In 5°C steps **
First letter	Lowest temperature from A = -40°C
Second letter	Highest temperature to Z = 85°C
Examples	
IS	0°C to 50°C
GU	-10°C to 60°C
EW	-20°C to 70°C

****Temperature Code Table**

Letter	Temp °C	Letter	Temp °C	Letter	Temp °C	Letter	Temp °C	Letter	Temp °C	Letter	Temp °C
A	-40	F	-15	K	10	P	35	U	60	Z	85
B	-35	G	-10	L	15	Q	40	V	65		
C	-30	H	-5	M	20	R	45	W	70		
D	-25	I	0	N	25	S	50	X	75		
E	-20	J	5	O	30	T	55	Y	80		

